

Gas Burner Safety Control

For 1- or 2-stage forced draught and atmospheric gas burners, with DC valves
Possible flame detectors:

- Ionisation probe
- Infrared flicker detector 1020.1
- UV flame sensor UVD 971

INTRODUCTION

The burner control boxes DVI980/982 controls and supervises forced draught and atmospheric gasburners. They are approved and certified according to the applicable European standards and regulations. The use on direct air heaters according DIN 4794 is also possible.

The microprocessor-based programming sequence ensures extremely stable timings independent of voltage variations, ambient temperature and/or switch-on cycles. The built-in information system not only provides a continuous monitoring of the actual state of the box (very helpful especially for monitoring the start-up phase) but also informs about the cause of a possible lock out. The lock out cause is stored in such a way that it can be retrieved even after a power failure. The control box is designed for maximum safety in case of fluctuations in the voltage supply. If the mains voltage drops below the permitted level, operation is interrupted and the control box automatically prevents the start sequence from being repeated. In this way, the safety of the system is not put at risk by a drop in the mains voltage. This low-voltage protection works not only during start-up but also permanently during operation.

CONSTRUCTION FEATURES

Microprocessor, electronic components, output relays, ignition spark generator and flame amplifier are placed on the printed circuit board.

These plus the optional lockout- and reset circuit are well protected inside a flame resistant plastic housing. The LED for displaying the information system are placed on top of the housing.

TYPES AVAILABLE

DVI 980	1-stage
DVI 982	2-stage

MODELS

The following functions can be configured by factory:

- with or without air proving switch
- IR-data transmission over Palm Pilot, PC or hand-held
- volatile or non volatile lock out
- recycling (numbers eligible) or lock out / blocked after loss-of-flame during operation
- recycling (numbers eligible) or lock out / blocked without flame establishment after safety time
- with or without internal reset button
- potential free output for flame signal
- with or without lock out lamp (LED)



TECHNICAL DATA

Operating voltage	220 / 240 V (-15... +10%) 50/60 Hz (±5%)
Fuse rating	10 A fast, 6 A slow
Power consumption	ca. 12 VA
Max. load per output	
- term. X2/6 motor	2.0 A, cos φ 0.4
Variation A	
- term. X3 ,X5, X6 solenoid valves	90mA, DC
Variation B	
- term. X3, X9, X5, X6 solenoid valves	90mA, DC
only DC-valves can be connected!	
- term. X2/8 lock out	1.0 A, cos φ 0.4
total load	max. 6 A during 0,5 sec
Air proving switch	1 working contact
STB Safety temperature delimiter	1 working contact
Ignition spark generator	
Ignition frequency	up to 40 Hz
Energy ignition spark	10 µAs
Ignition voltage	20 kV
Sensitivity (operation)	1 µA
Min. required ion. current	1.5 µA
Sensitivity for stray light	0.4µA
Flame signal output	Optocoupler max 70V DC/100mA
Ionisation probe insulation	Probe - earth greater than 50 MΩ
Stray capacity	Probe - earth less than 1000 pF
Cable length	< 3 m
Flame detectors	
IRD 1020.1	end-on viewing
UVD 971	end-on viewing
Weight incl. Wiring base	190 g
Mounting position	any
Protection class	IP 40
Approved ambient parameter	
- for operation	-20° C... +60° C
- for storage	-20° C... +80° C
Build-up of ice, penetration of water and condensing water are inadmissible	
Approvals according	to European standard EN 298, as well as all other relevant Directives and standards

Table of timings (sec.)

Model	max. reaction time or air proving switch tlw	supervised pre-purge time tv1	pre-ignition time tvz	ignition time total tz	stray light monitoring tf	safety time ts	delay 2nd stage (DVI 982) tv2
01	60	24	0	4	5	5	10
02	60	10	0	4	5	5	-
05	60	30	0	4	5	5	-

APPLICATION FEATURES

1. Information system

The information system is microprocessor based and reports on all aspects of burner control box operation and flame supervision. It informs continuously about the actual programming sequence the unit is just performing. Besides monitoring of the programming sequence it also allows to identify errors during start-up of operation without any additional testing devices. The automatically performed diagnosis is a valuable tool which facilitates service/maintenance work and therefore saves costs. The analyses of the error cause can be done directly on stage or if not possible afterwards as the lock out reason is stored in a non-volatile lock out mode memory.

The information system communicates with the outside world using a LED (the used Flash-Code is similar to the Morse-Code). The messages are optically transmitted by a appropriately flashing LED. Using an additional terminal (optional), the messages can be recorded and displayed in easy readable form.

1.1 Programming sequence display

The built-in microprocessor controls not only the programming sequence but the information system too. The individual phases of the programming sequence are displayed as Flash-Code.

The following messages can be distinguished:

Message	Flash-Code
waiting for air proving switch	.
pre-purge tv1	.
pre-ignition tvz	.
safety time ts	■ .
delay 2nd stage tv2	■ .
running	_
low mains voltage	■ ■ _
Internal fuse defect	■ _
> control box defect	

Description

| = short pulse
 ■ = long pulse
 . = short pause
 _ = long pause

1.2 Lock-out diagnoses

In case of a failure the LED is permanently illuminated. Every 10 seconds the illumination is interrupted by a flash code, which indicates the cause of the error. Therefore the following sequence is performed which is repeated as long as the unit is not reset.

Sequence:

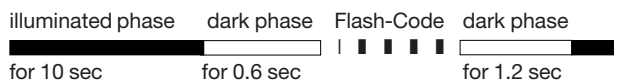

Error diagnosis:

Error message	Flash-Code	Possible fault
lock out	■ ■ ■ ■	within safety time
safety time		no flame establishment
stray light	■ ■ ■	stray light during monitored phase, detector may be faulty
air proving switch in closed position	■ ■	air proving switch contact welded
air proving switch time-out	■ ■	air proving switch does not close within specified time
air proving switch opened	■	air proving switch opens during start or operation
loss of flame	■ ■ ■ ■	loss of flame signal during operation

Flash-Code for manual lock out

manual/external lock out	■ ■ ■ ■ ■ ■ ■ ■
(see also 3. lock out and reset)	
Error RV1 or STB opens	■ ■ ■ ■ ■ ■ ■ ■
Safety temperature delimiter STB opens. For reset, the supply line must, for a short time, be interrupted after pushing the reset button.	

2. Flame detection

The following types of flame detectors are suitable:

- Ionisation probe, temperature resistant material, well insulated (material and insulation same as for ignition electrode).
 - Infrared-flicker detector type IRD 1020.1 with mounting flange M 93 or the UV solid state flame sensor UVD 971.
- Flame detection using an ionisation probe is only possible in conjunction with mains supplies which provides a neutral earth connection. Connecting the IRD 1020.1 or UVD 971 the correct wiring has to be observed.

2.1 Stray light monitoring

The stray light check is performed at the end of the pre-purge time for the duration as mentioned in the table of timings.

3. Lock out and reset

The unit can be reset or brought into lock out mode in two different ways:

Internal (optional)

In the lock out case the unit can be reset by pushing the reset button meaning a new start-up cycle is performed.

External

Instead of using the reset lock out button the same function can be achieved by using an external button which connects terminal X2/12 with X2/9 (see also circuit and block diagram).

Models with volatile lock out also can be reset by a short-time interrupt of the supply line.

If the pushbutton (internal or external) is pressed during normal operation or during the start sequence for more than 3 sec. and afterwards released, the control box will perform a shutdown.



Please note

The unit can only be brought to lockout mode or be reset if power is applied to the unit.

Don't apply to units with volatile lock out.

4. Low-voltage protection

The mains voltage has to be more than $193 V_{eff}$ in order to allow the unit to perform a start-up.

The mains voltage is not only monitored in the start-up phase but also permanently during operation. If the voltage drops below $< 175 V_{eff}$ during start-up or run time the control box proceed to safety shut-down and goes into a waiting status. If the voltage rises again, the control box performs automatically a start-up as soon as the mains voltage is $> 193 V_{eff}$.

5. Safety

The design and control sequence of the DVI980/982 controls will comply with the currently applicable standards and regulations (see also TECHNICAL DATA).

6. Mounting and electrical wiring

The DVI 980/982 is put directly on the solenoid valve. Molex plug connector 3003 for:

- Power supply line
- Control thermostat RT
- Air proving switch LW
- Motor M
- External lock out signal
- Safety temperature delimitter STB
- External reset and lock out button

Counterpart:

- Molex plug connector 3001

General

The control box and the sensor shall not be exposed to excessive vibrations.

7. Model functions

The following functions are configured by factory

Model 01:

- **with air proving switch**
- IR-data transmission over Palm Pilot, PC or hand-held
- non volatile lock out, no reset with interrupt of the supply line
- direct lockout after loss of flame during operation
- direct lockout if no flame established after safety time
- with internal reset button
- without potential free output for flame signal
- **Circuit diagram:** "valve supply over air proving switch contact", variation A, see page 5)

Model 02:

- **with air proving switch**
- IR-data transmission over Palm Pilot, PC or hand-held
- non volatile lock out, no reset with interrupt of the supply line
- altogether 2 times recycling if no flame established after safety time or loss of flame during operation
- without internal reset button
- potential free output for flame signal
- **Circuit diagram:** "valve supply not over air proving switch contact", variation A, see page 5)
- with internal lock out lamp (LED)

Model 05:

- **with air proving switch**
- IR-data transmission over Palm Pilot, PC or hand-held
- volatile lock out, reset with interrupt of the supply line
- altogether 2 times recycling if no flame established after safety time or loss of flame during operation
- without internal reset button
- potential free output for flame signal
- **Circuit diagram:** "valve supply over air proving switch contact", variation A, see page 5)
- with internal lock out lamp (LED)

INSTALLATION INSTRUCTIONS AND MAINTENANCE

1. Important notes

- The controls must be installed by qualified personnel only. The relevant national regulations have to be observed.
- On commissioning the wiring has to be carefully checked according the appropriate diagram, Incorrect wiring can damage the unit and endanger the installation.
- The fuse rating has to ensure that the limits specified in TECHNICAL DATA will not be exceeded. If these precautions are not observed, the effect of a short circuit can cause severe damage to the control and installation.
- For safety reasons a minimum of one control shutdown per 24 hours has to be observed.
- Disconnect the mains before the control box is plugged in or out.
- The control box is a safety device and must not be opened!

2. Function control

For safety reasons the flame detection system should be tested on commissioning the installation as well as after a service or longer shut-down.

- Start-up with closed gas valve
 - for direct lockout operation, after safety time is over the unit has to go into lock out mode!
 - for recycling operation (max. recycling limited) carry out a re start-up.
- Normal start-up, when burner is running, close gas valve
 - for direct lockout operation, after loss of flame the control box has to go into lockout mode!
 - for recycling operation (max. recycling limited) carry out a re start-up.
- Normal start-up, during pre-purge or operation, interrupt the air proving switch
 - for direct lockout operation, the control box has to go into lockout mode immediately!
 - for recycling operation (max. recycling limited) carry out a re start-up.
- Bridged air proving switch before start
 - the fan motor switches on for approx. 2 - 3 sec., followed by a lockout. After 10 sec., this quick lockout is resetted by the control box and a second start attempt follows (fan motor switches on for approx. 2 - 3 sec.). A standard lockout appears if the air proving switch (LW) contact is still in it's closed position (e.g. welded contacts). Has the air proving switch (LW) changed to it's open position in the meantime (e.g. by a run down motor), a normal start sequence follows.

3. Fault finding

The built-in information system facilitates the trouble shooting in the case of problems occurring during start-up or during operation.

A list of possible lock out messages can be found in APPLICATION FEATURES chapter 1.2.

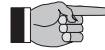

Please note:

The control box is locked in lock out mode and the reason for the lock out is displayed until the control box is reset, either by an internal or external reset (see also subject "3. Lock out and reset").

Interrupting the supply line (by models with non volatile lock out) may not reset a lock out. Therefore, by applying power, the fan motor switches on for 2-3 secs. before the control box goes to lock out again in cause of the last lock out.

Error	Possible fault
Burner not working	- Thermostat circuit open - Faulty electrical wiring - Mains voltage < 193 V
Fan motor starts for a short period of time, control box goes to lock out	- Control box has not been reset - Air proving switch not in open position
Control box locks out or recycled during pre-purge	- Air proving switch has not closed within 60 sec. - Air proving switch has re-opened
Control box locks out or recycled at the end of pre-purge	- Air proving switch open - Flame signal (stray light)
Burner starts, flame not established, after safety time lock out or recycling	- No ignition or no gas
Burner starts, flame established, after safety time lock out or recycling	- No or to low flame signal (flame does not stick, bad insulation of the ionisation probe, bad connection to frame ground) - Insufficient light on IRD or UVD - Sensitivity adjustment to low on IRD

CIRCUIT AND TIMING DIAGRAM DVI 980/982



Using only the connection diagram for the wiring which is noted down for the respective model variation (see "7. model functions", page 3).
A wrong wiring leads to malfunctions!

Valve supply not over air proving switch contact

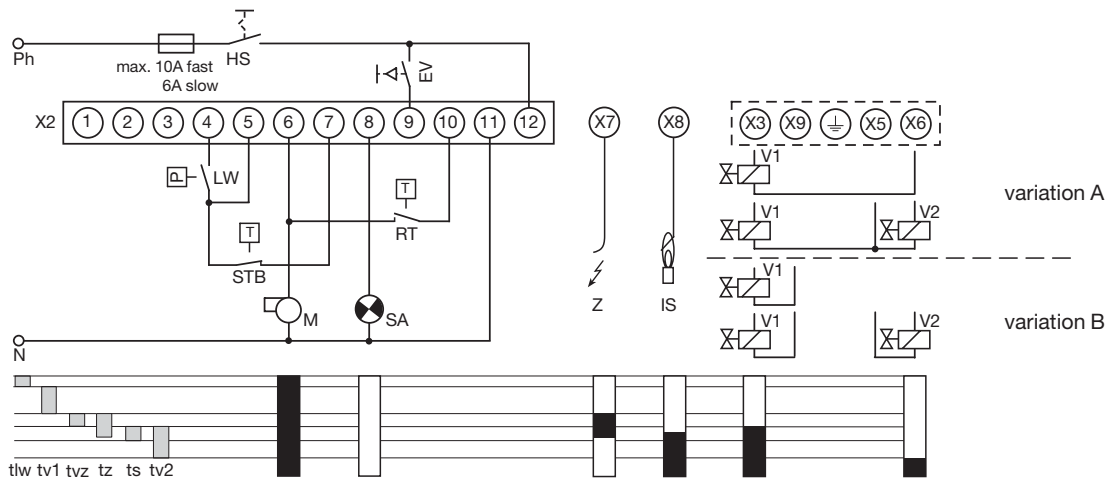

Without air proving switch

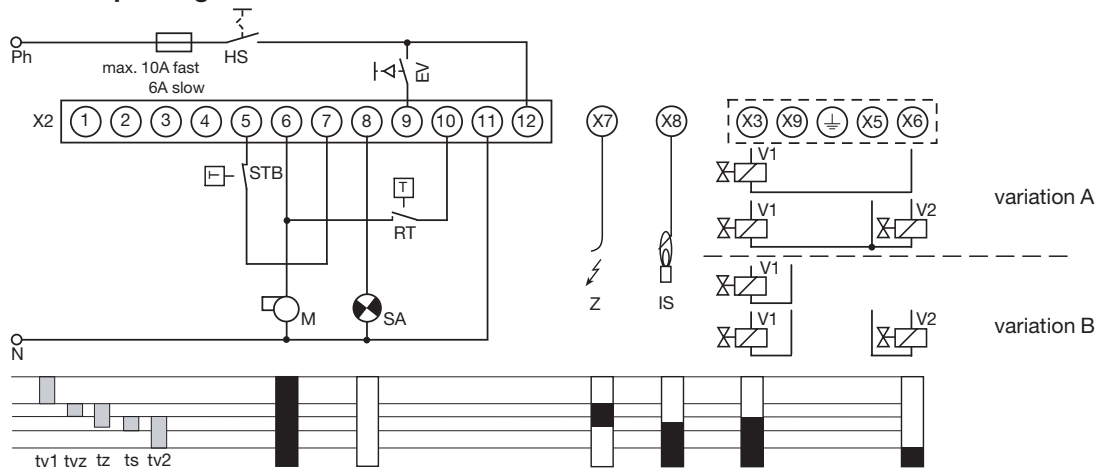

Valve supply over air proving switch contact

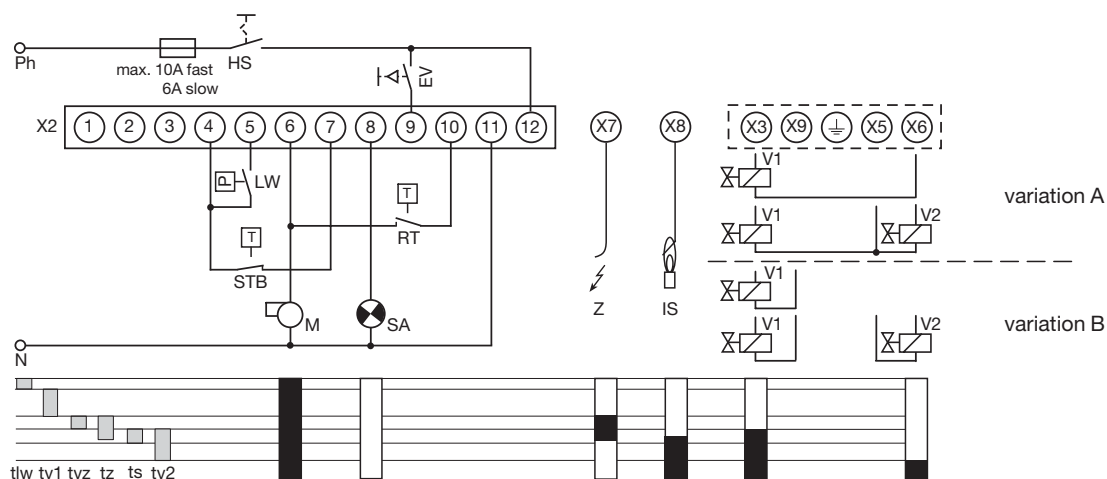

IRD- OR UVD CONNECTION

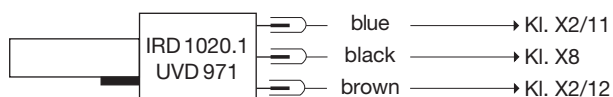

HS	Mains switch	Z	Ignition probe
EV	External reset and lock out button	V1	Solenoid valve 1st-stage
RT	Control thermostat	V2	Solenoid valve 2nd-stage
LW	Air proving switch		
STB	Safety temperature delimiter Using wire link for application without STB.	tlw	Max. reaction time for air proving switch
M	Motor	tv1	Supervised pre-purge time
SA	External lock out signal	tv2	Pre-ignition time
IS	Ionisation probe (IRD 1020.1, UVD 971 see separate diagram)	tz	Ignition time total
		ts	Safety time
		tv2	Delay 2nd-stage

BLOCK DIAGRAM DVI 980/982

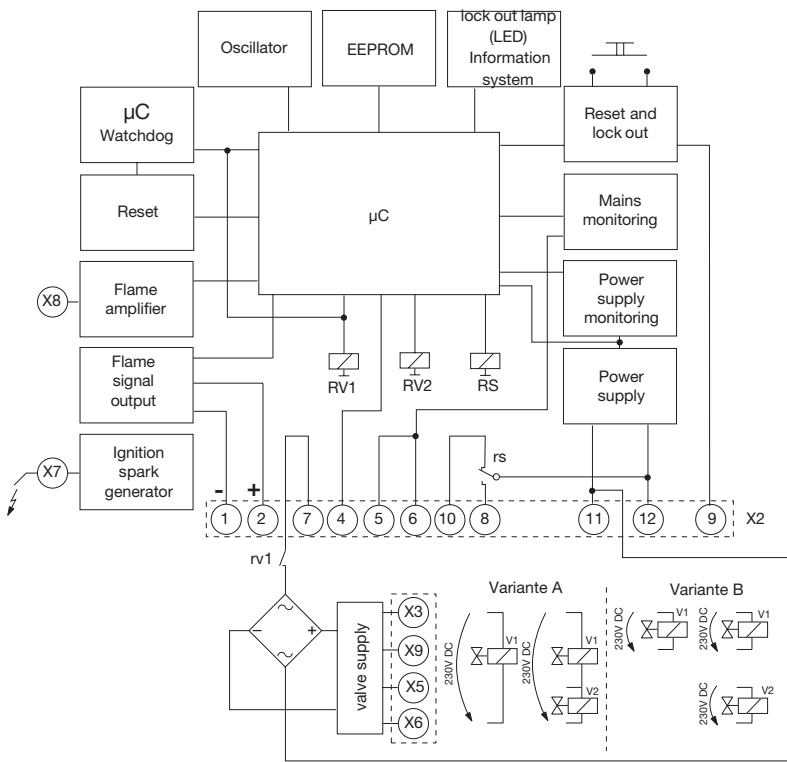

Note:
Equipment for connection version A is fitted differently to version B.
-> no exchange possible!

DIMENSION DVI 980/982

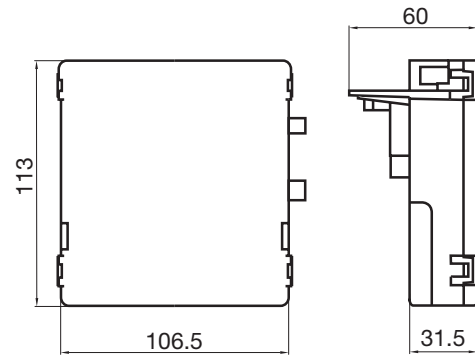

UVD 971

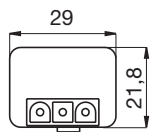

IRD 1020.1

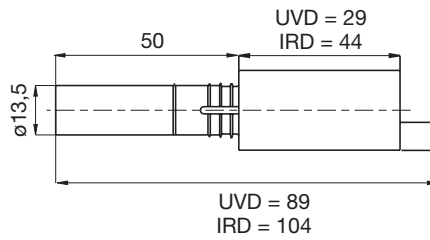
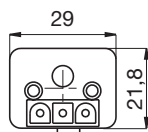

HOLDER M 93 FOR IRD

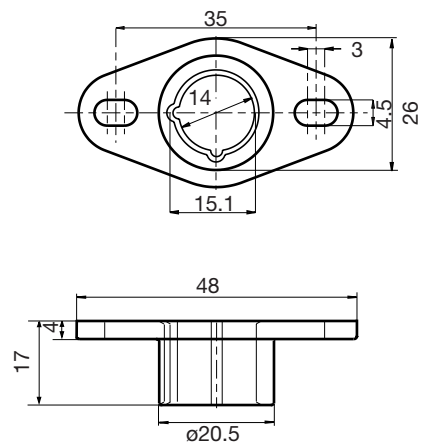

ORDERING INFORMATION

ITEM	DESIGNATION	ITME NO.
Control box	DVI 980 Mod. 02	0390602
Control box	DVI 980 Mod. 05	0390605
Flame detector	IRD 1020.1 D end-on	16552
or	UVD 971	16722
Holder IRD	Holder M 93 for IRD 1020.1	59093
Holder UVD	Holder M 74 for UVD 971	59074
Connection cable	Plug-type, 3-core cable, 0.6 m with tag wire end	7236001

The above ordering information refers to the standard version.
Special versions are also included in our product range.

Specifications subject to change without notice

DVI 980/982

A Honeywell Company

Satronic AG
Honeywell-Platz 1
Postfach 324
CH-8157 Dielsdorf