

Linear actuator for adjusting air dampers and sliders in ventilation and air-conditioning systems for building services installations

- For air dampers up to approx. 0.8 m<sup>2</sup>
- Actuating force 125 N
- Nominal voltage AC 100 ... 240 V
- Control: Open-close or 3-point



### Overview of types

Type	Stroke
CH230-L60	Up to approx. 60 mm, adjustable in 0.5 mm increments
CH230-L100	Up to approx. 100 mm, adjustable in 0.5 mm increments

### Technical data

<b>Electrical data</b>	Nominal voltage	AC 100 ... 240 V, 50/60 Hz
	Nominal voltage range	AC 85 ... 265 V
	Power consumption	In operation 1.5 W @ nominal torque At rest 1 W For wire sizing 3 VA
	Connection	Cable 1 m, 3 x 0.75 mm <sup>2</sup>
<b>Functional data</b>	Actuating force (nominal force)	Min. 125 N @ nominal voltage
	Negative torque	⚠ The following restriction applies if end stop clips (Z-ESCM) are used: ≤50% from nominal torque (Caution: can only be used with restrictions. Please contact your Belimo representative.) There are no restrictions if end stops are used on the gear rack or the application.
	Stroke	See «Overview of types»
	Direction of stroke	Can be selected through contact assignment
	Stroke limiting	Without limit 60 / 100 mm With limit 60 mm fixed or 0 ... 67.5 mm by means of mechanical end stop, adjustable in 0.5 mm increments (calculatory 0.55 mm)
	Running time	380 s / 100 mm
	Sound power level	Max. 35 dB (A)
<b>Safety</b>	Protection class	II totally insulated <input type="checkbox"/>
	Degree of protection	IP54 in any mounting position
	EMC	CE according to 2004/108/EC
	Low voltage directive	CE according to 2006/95/EC
	Certification	Certified to IEC/EN 60730-1 and IEC/EN 60730-2-14
	Mode of operation	Type 1
	Rated impulse voltage	2.5 kV
	Control pollution degree	3
	Ambient temperature	-30 ... +50 °C
	Non-operating temperature	-40 ... +80 °C
	Ambient humidity	95% r.h., non-condensating
	Maintenance	Maintenance-free
<b>Dimensions / Weight</b>	Dimensions	See «Dimensions» on page 3
	Weight	Approx. 390 g

## Safety notes



- The actuator is not allowed to be used outside the specified field of application, especially in aircraft or in any other airborne means of transport.
- **Caution: Power supply voltage !**
- It may only be installed by suitably trained personnel. Any legal regulations or regulations issued by authorities must be observed during installation.
- The device may only be opened at the manufacturer's site. It does not contain any parts that can be replaced or repaired by the user.
- The rotary supports and coupling pieces available as accessories must always be used if lateral forces are likely. An additional installation sheet is required in accordance with the installation instructions.  
In addition, the actuator must not be tightly bolted to the application. It must remain movable via the rotary support (refer to «Assembly notes»).
- If the linear actuator is exposed to severely contaminated atmosphere, appropriate precautions must be taken on the system side. Excessive deposits of dust, soot etc. can prevent the gear rack from being extended and retracted correctly.
- If not installed horizontally, the magnet-operated gear disengagement may only be actuated when there is no pressure on the gear rod.
- To calculate the actuating force required for air dampers and sliders, the specifications supplied by the damper manufacturers concerning the surface, cross section, design, installation site and the air flow conditions must be observed.
- If a rotary support and/or coupling piece is used, losses in the actuation force are to be expected.
- The device contains electrical and electronic components and is not allowed to be disposed of as household refuse. All locally valid regulations and requirements must be observed.

## Product features

<b>Manual override</b>	Manual override with magnet possible (the gear is disengaged as long as the magnet adheres to the symbol ⊗). A magnet for gear disengagement is enclosed as an accessory.
<b>Adjustable stroke</b>	The stroke can be adjusted on both sides in 0.5 mm increments by means of mechanical end stops.
<b>High functional reliability</b>	The actuator is overload-proof, requires no limit switches and automatically stops when the end stop is reached.

## Accessories

	Description	Data sheet
<b>Mechanical accessories</b>	Rotary support to compensate lateral forces Z-DS1	T2 - Z-LH..A..
	Coupling piece Z-KS2	T2 - Z-LH..A..
	End stop set Z-AS2	T2 - Z-LH..A..
	Magnet Z-MA (multipack with 20 pcs. each)	
	Endstop Clip Z-ESCM (multipack with 20 pcs. each)	

## Electrical installation

### Wiring diagrams

#### Notes

- Caution: Power supply voltage !
- Other actuators can be connected in parallel. Note the performance data.



### Open-close control

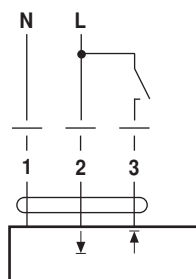

### 3-point control

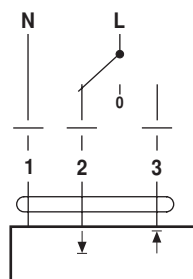

### Assembly notes

#### Application without lateral forces

The linear actuator is screwed directly to the housing at two points. Afterwards, the head of the gear rod is fastened to the moving part of the ventilation application (e.g. damper or slider).

#### Application with lateral forces

The coupling piece with the internal thread (Z-KS2) is connected to the head of the gear rod. The rotary support (Z-DS1) is screwed to the ventilation application. Afterwards, the linear actuator is screwed to the previously mounted rotary support with the enclosed screw. Afterwards, the coupling piece, which is mounted to the head of the gear rod, is attached to the moving part of the ventilation application (e.g. damper or slider). The lateral forces can be compensated to a certain limit with the rotary support and/or coupling piece. The maximum permissible swivel angle of the rotary support and coupling piece is  $10^\circ$  , laterally and upwards.

#### Caution

If a rotary support and/or coupling piece is used, losses in the actuation force losses are to be expected.



### Dimensions [mm]

#### Dimensional drawings

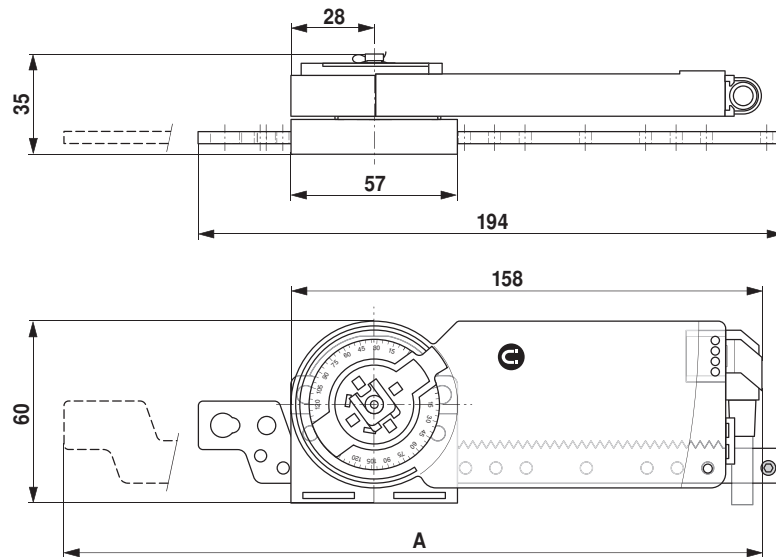

Type	Max. stroke	A
CH230-L60	60	248
CH230-L100	100	288

71226-00060.A

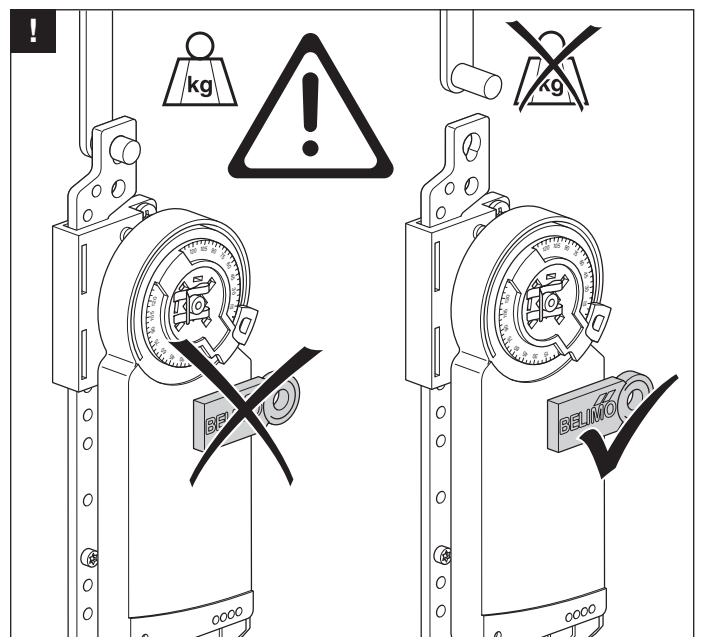
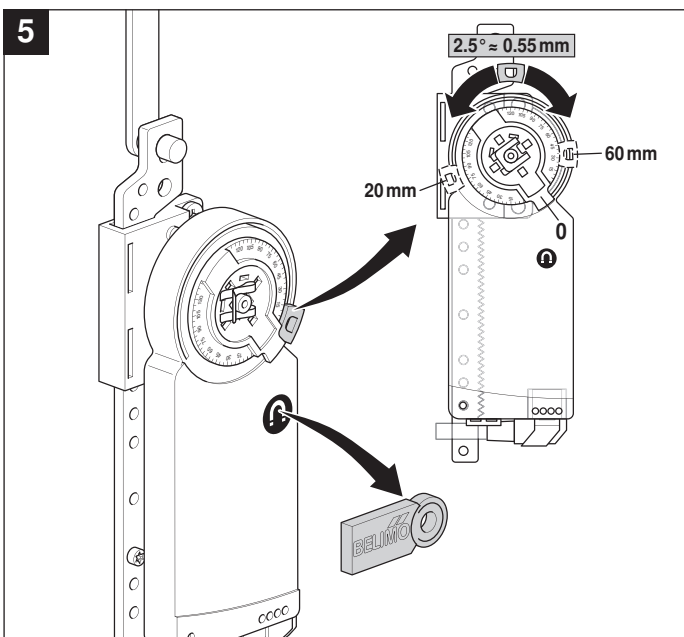
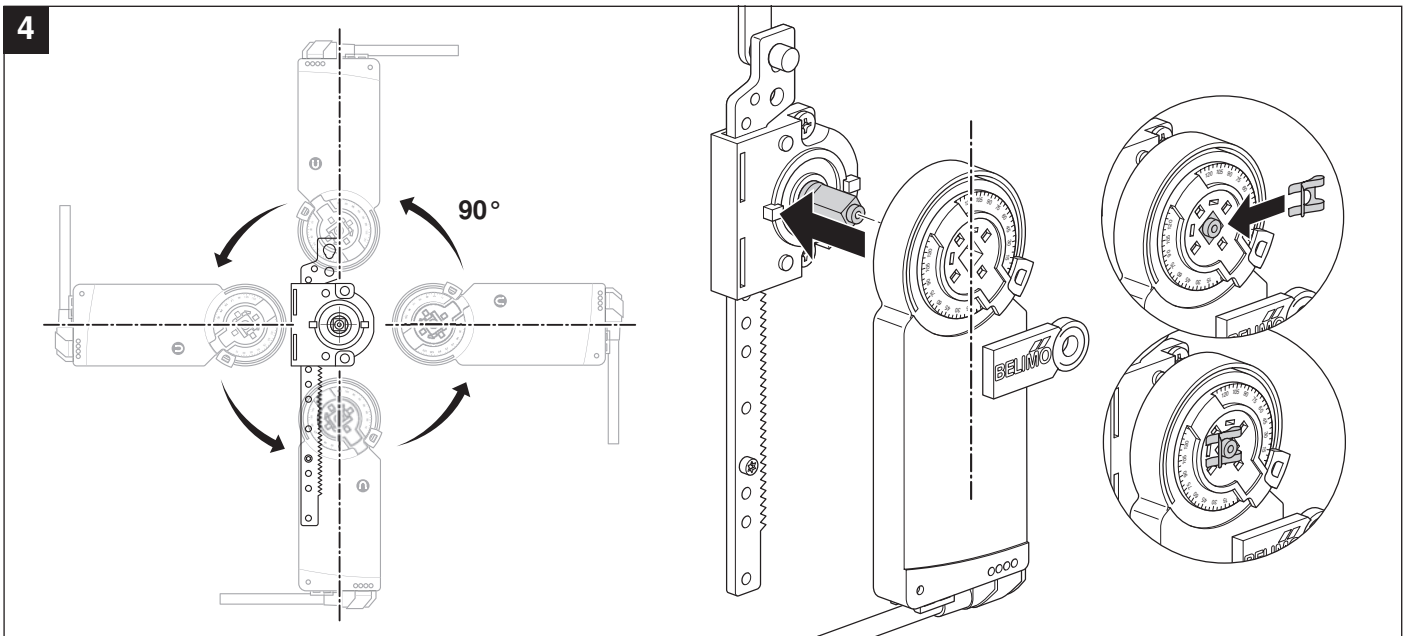
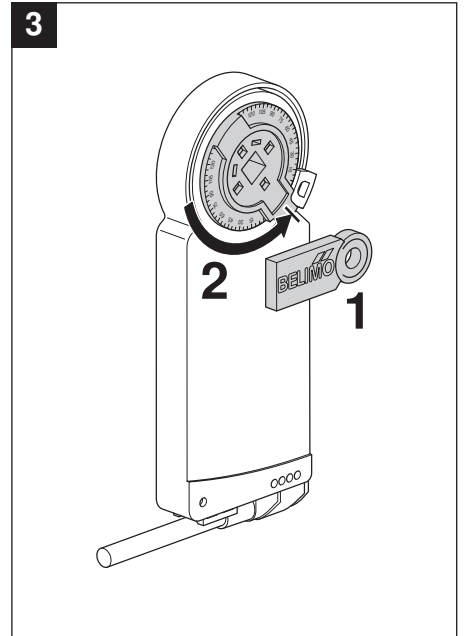
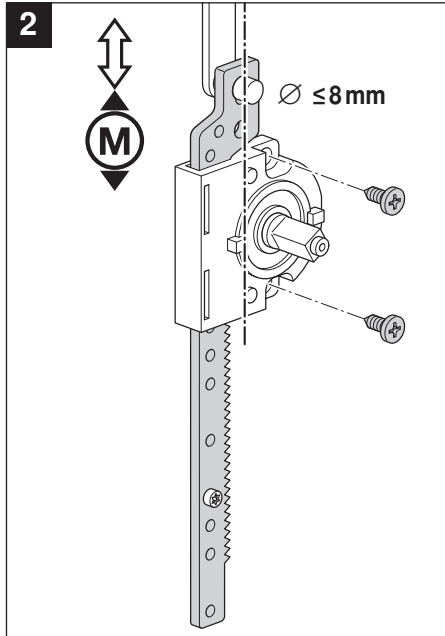
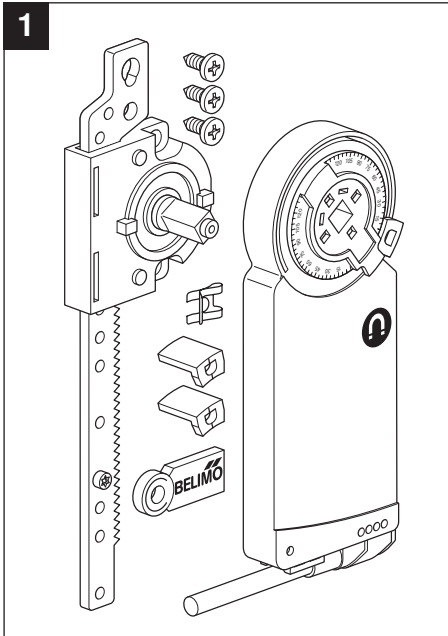

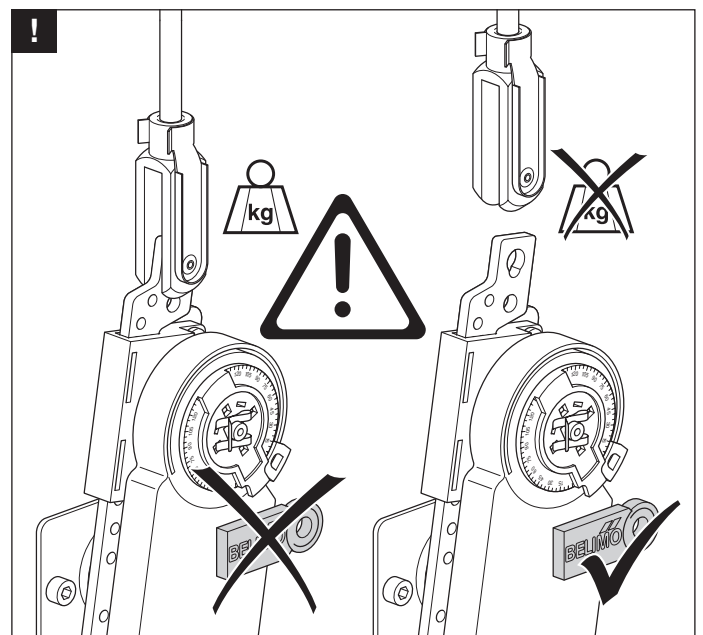
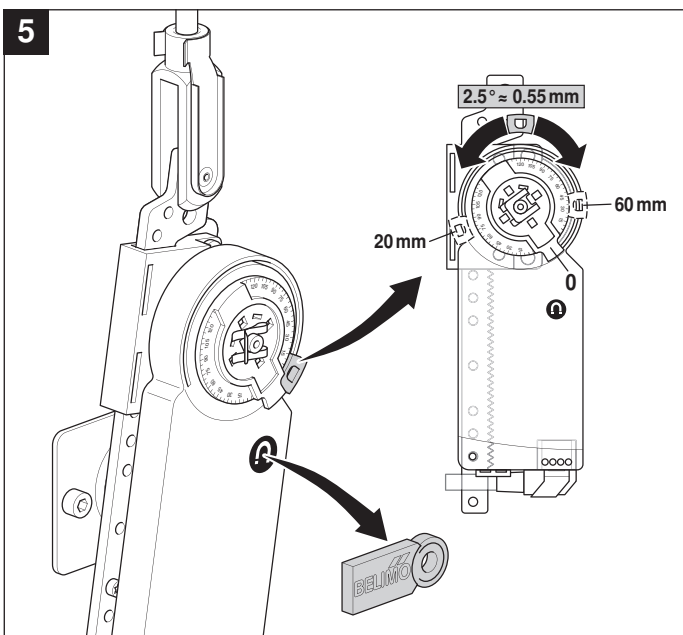
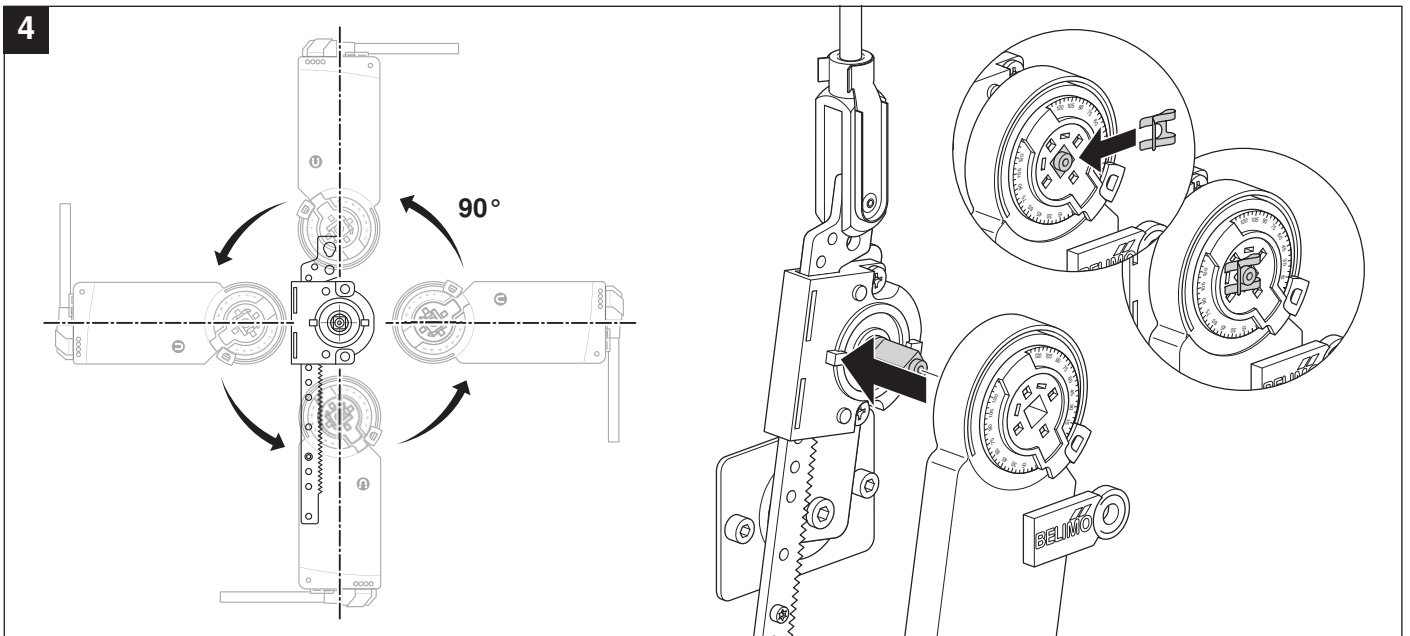
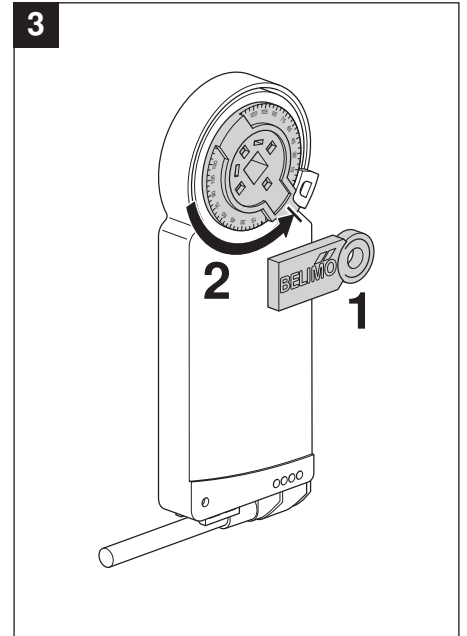
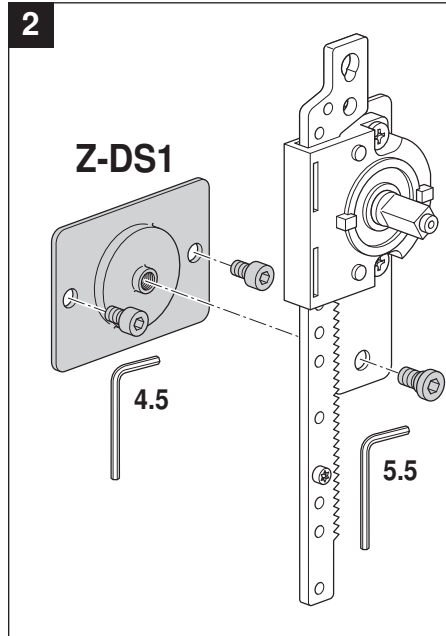
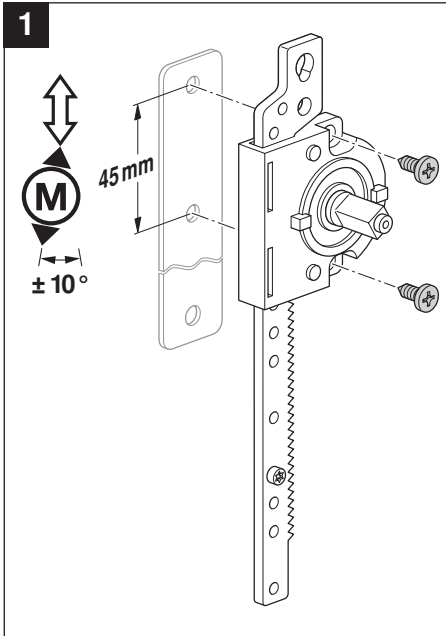

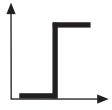

AC 24 V / DC 24 V

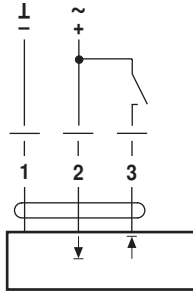

CH24-L60

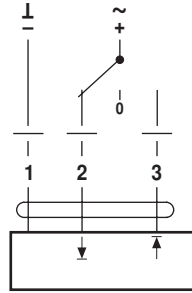

CH24-L60

AC 100 ... 240 V

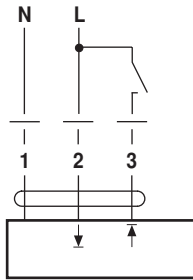

CH230-L60

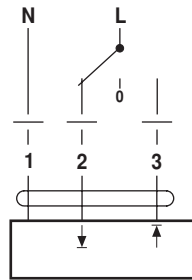

CH230-L60

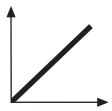

AC 24 V / DC 24 V

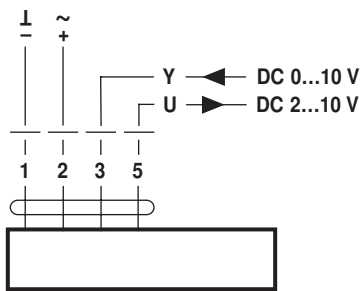

CH24-SR-L60

71226-00001.A

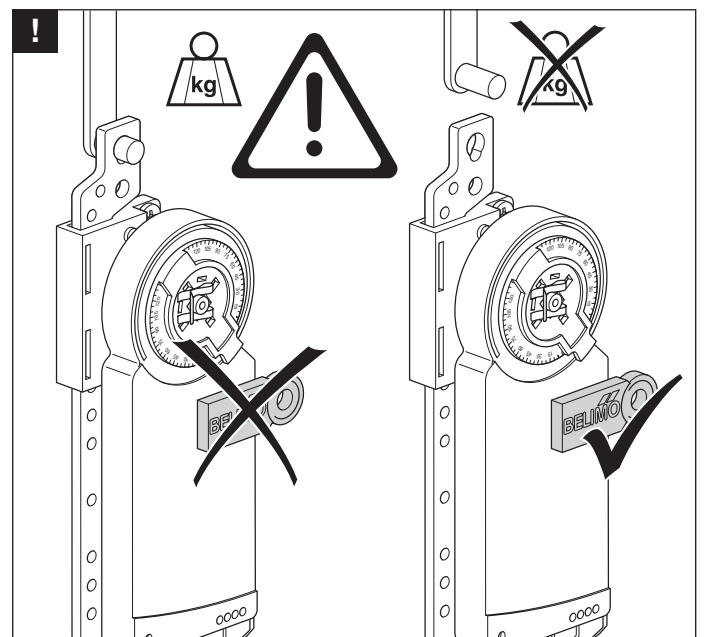
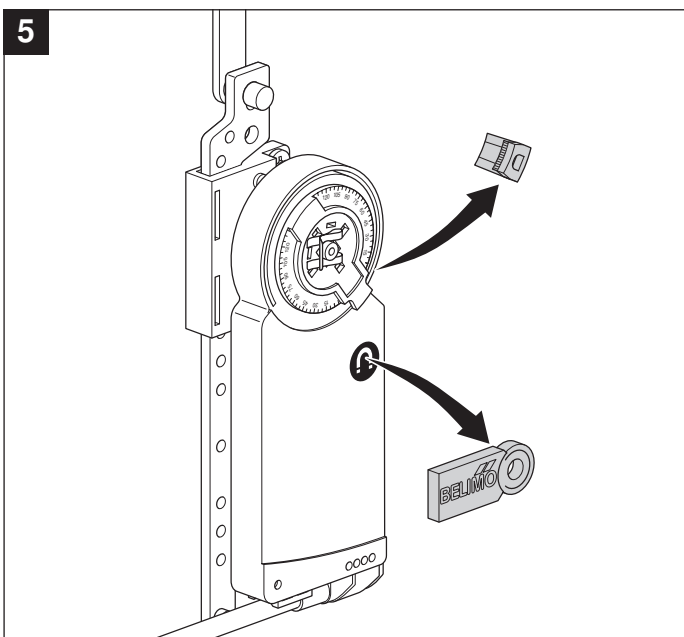
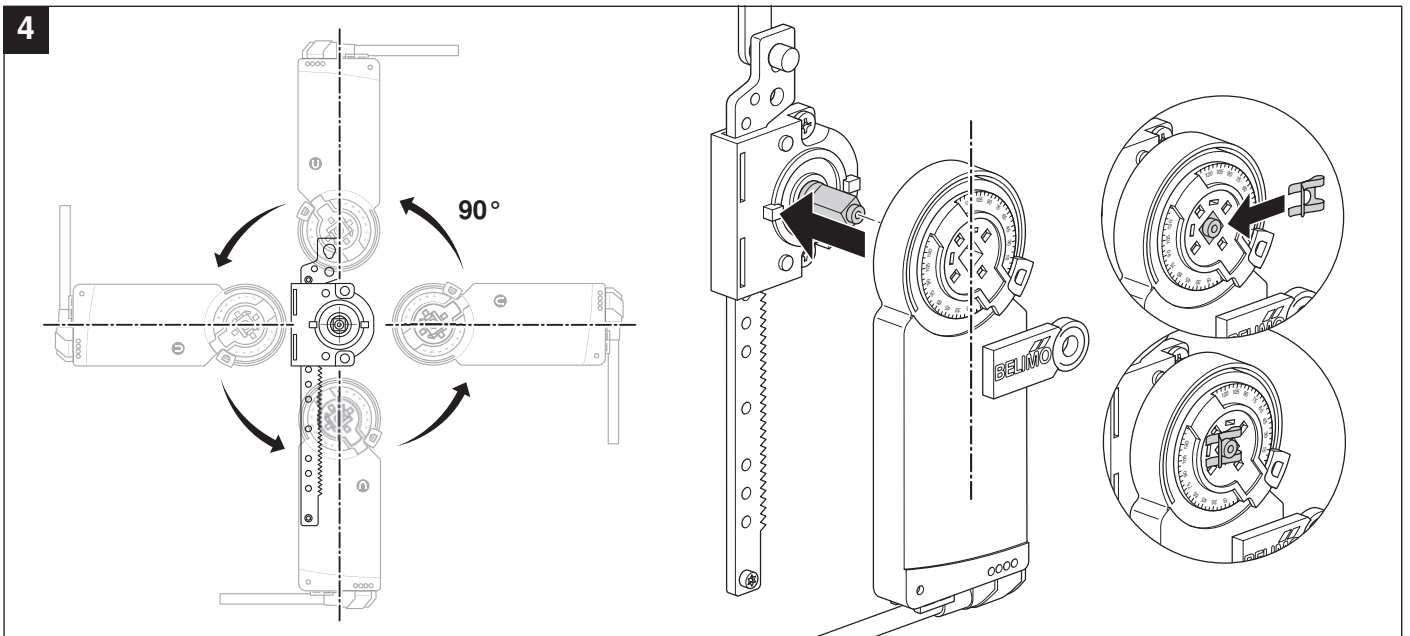
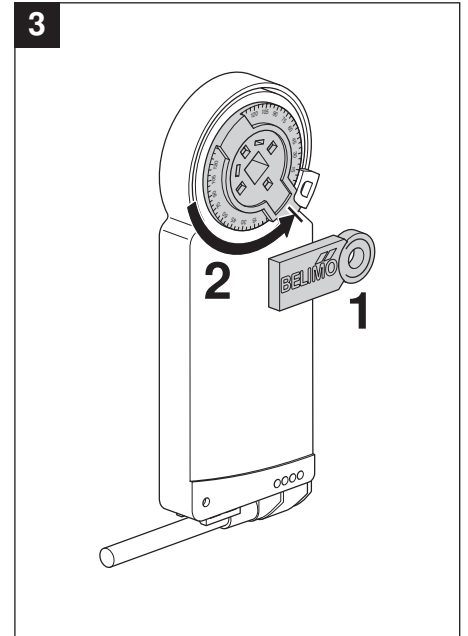
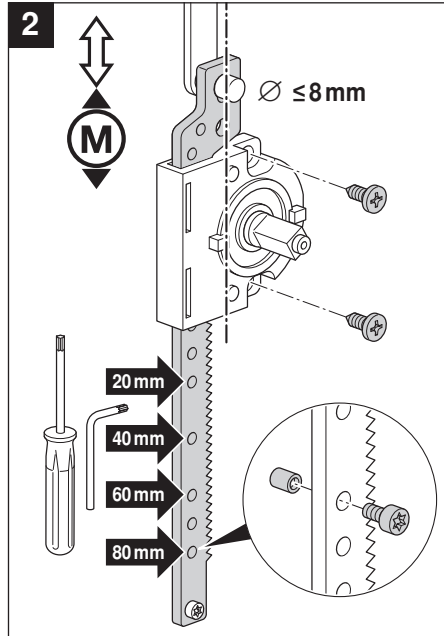
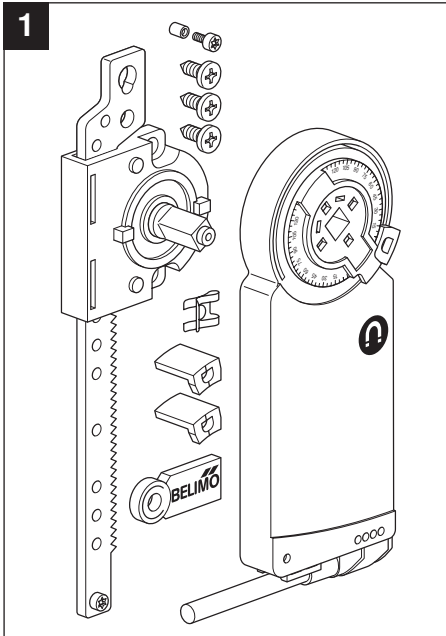



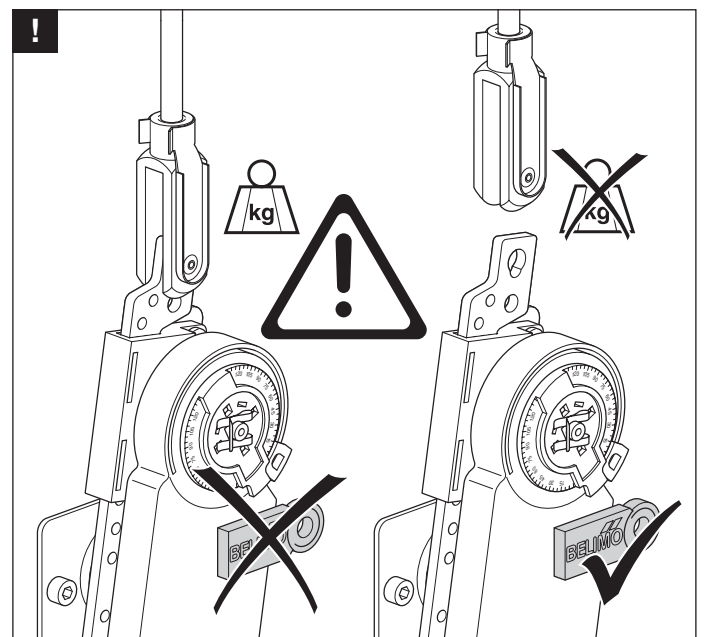
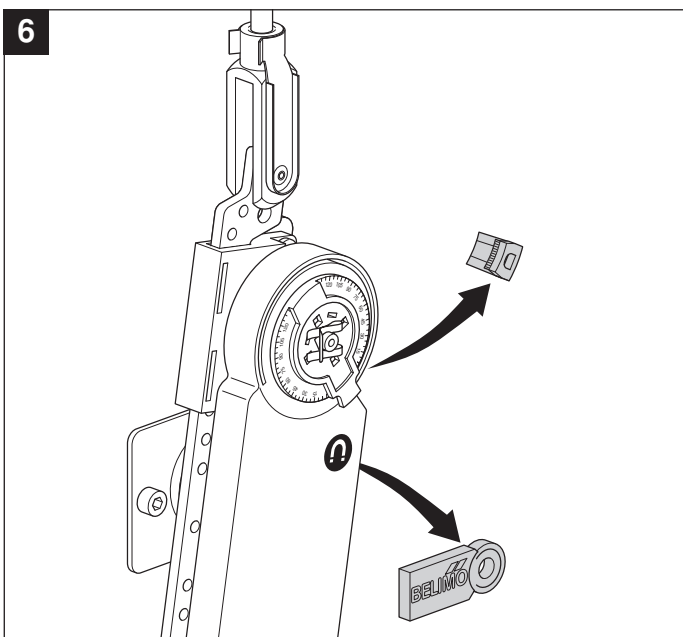
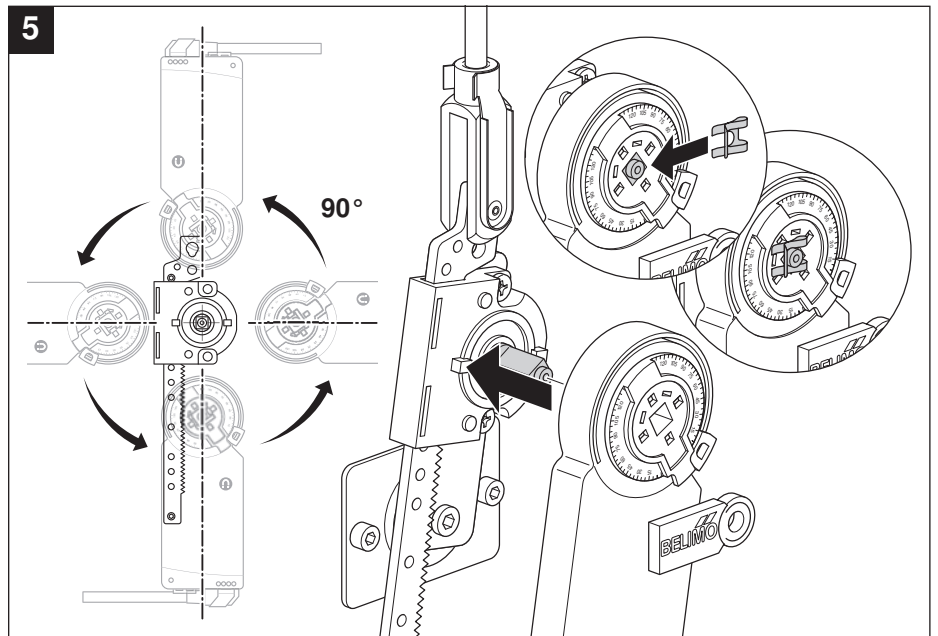
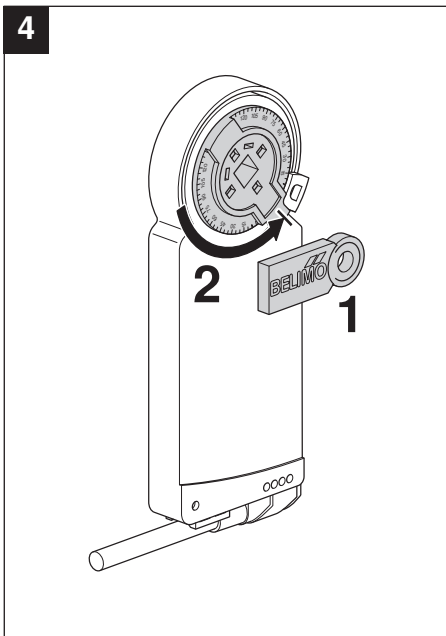
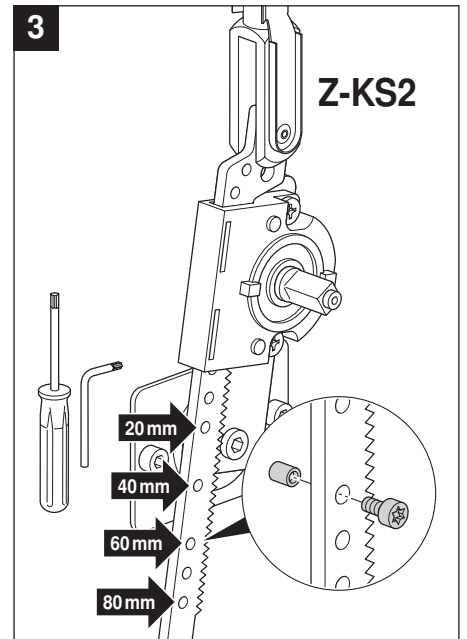
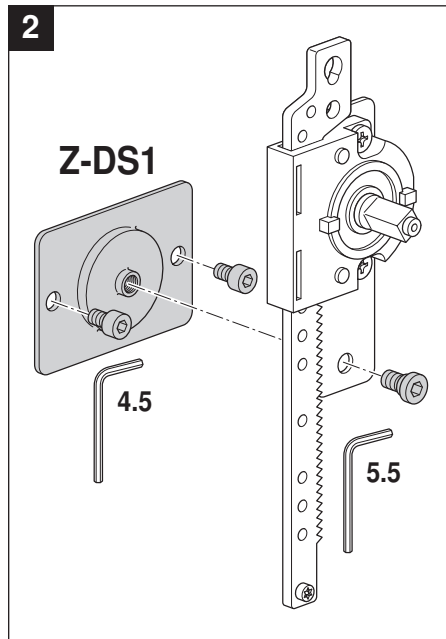
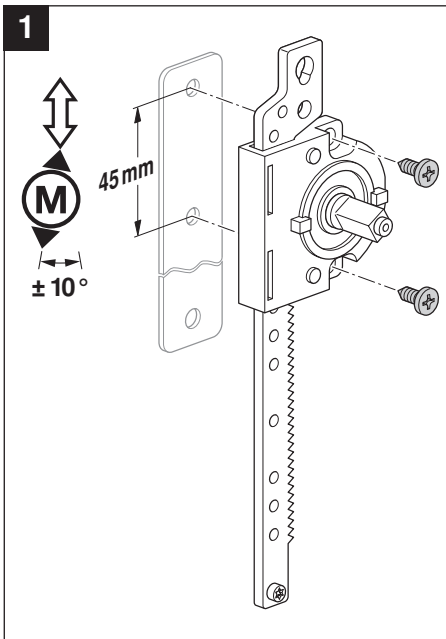



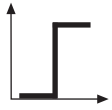

AC 24 V / DC 24 V

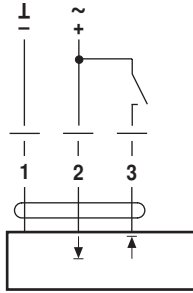

CH24-L100

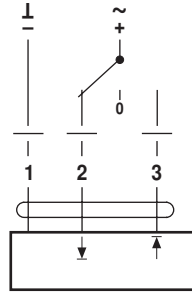

CH24-L100

AC 100 ... 240 V

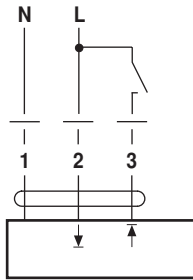

CH230-L100

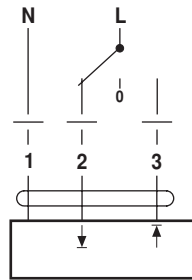

CH230-L100

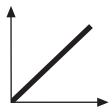

AC 24 V / DC 24 V

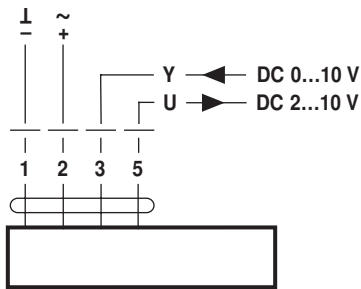

CH24-SR-L100