

ATEX Product Range

ATEX II3GD

Safety solenoid valves, one-level

MV ... X, MVD ... X

Differential pressure switch

GGW...A4/2 X

GGW...A4-U/2 X

High-pressure switch

GW...A4/2 HP X

DUNGS®
Combustion Controls



ATEX

The abbreviation **ATEX** stands for the French term "Atmosphère explosible" and is used as synonym for the two EU directives concerning explosion protection:

Equipment directive 94/9/EC
Workplace directive 1999/92/EC

ATEX product range

The equipment of the DUNGS ATEX product range complies with equipment group II, category 3 for gas and dust. It may only be used in zones 2 and 22.

Approvals/declaration of conformity

DUNGS issues a manufacturer's declaration of conformity for all equipment of the ATEX product range.

The used equipment has an EC type-examination certificate according to the EC gas appliance directive and EC pressure equipment directive based on the corresponding harmonised EN standards.

DUNGS ATEX product range

Products	Page	for use in	
		Category: II3G Zone 2, gas	Category: II3D Zone 22, dust
Single solenoid valve, one stage operation MV ... X, MVD ... X	4		✓
Differential pressure switch GGW...A4/2 X, GGW...A4-U/2 X	8		✓
High-pressure switch GW...A4/2 HP X	8		✓
Valve proving system VPM-VC, DSLC pxVx 24 V DC (if installed outside of the explosive atmosphere)			✓



ATEX Equipment directive 94/9/EC

Directive 94/9/EC concerning equipment and protective systems intended for use in potentially explosive atmospheres. It determines rules for placing products, which are intended for use in potentially explosive atmospheres, on the market. For the first time, non-electrical equipment is covered by this directive. Turning couplings, for example, can create a risk of ignition due to inadmissibly high warming.

Annex II of this directive contains the general requirements concerning health and safety protection to be observed by the manufacturer and to be proven by means of the corresponding conformity assessment procedures.

ATEX Workplace directive 1999/92/EC

Determination of minimum requirements for improving the safety and health protection of workers potentially at risk from explosive atmospheres. This directive contains basic safety requirements that must be implemented by the operator/employer. These include:

- **Primary explosion protection**
Prevention or limitation of the formation of explosive atmospheres
- **Secondary or constructive explosion protection**
Avoidance of effective ignition sources
- **Tertiary explosion protection**
Mitigation of the detrimental effects of an explosion to a harmless degree

The purpose of this directive is the protection of persons working in potentially explosive atmospheres.

Explosion protection document

The employer/operator shall create an **explosion protection document** within his **risk assessment** and divide areas with hazardous, potentially explosive atmosphere into **zones**. He shall create an **Ex zone plan** representing the extension of each individual zone and, if necessary, the overall dimensions.

The explosion protection document shall demonstrate in particular:

- that the explosion risks have been determined and assessed
- a list of measures taken in order to prevent explosions
- the division of areas with potentially explosive atmospheres into zones (Ex zone plane)
- compliance with minimum requirements

The form of the explosion protection document is not prescribed. All relevant documentation that might be useful for evaluating an explosion hazard may be added to the explosion protection document:

Registers of hazardous substances, user manuals of the used equipment according to ATEX Equipment directive 94/9/EC, operating instructions, organisational measures, risk assessments, alarm and risk prevention plan.

The operator is solely responsible for the safety of his installation:

- Creation of the installation-specific explosion protection document
- Determination of the zones
- Use of equipment conform to a certain zone
- Proper installation
- Examination prior to putting into service
- Regular check and maintenance of the installation in order to maintain the proper condition of the overall installation.

Definition of ATEX terms					
Equipment	'Equipment' means machines, apparatus, fixed or mobile devices, control components and instrumentation thereof and detection or prevention systems which, separately or jointly, are intended for the generation, transfer, storage, measurement, control and conversion of energy for the processing of material and which are capable of causing an explosion through their own potential sources of ignition.				
Components	'Components' means any item essential to the safe functioning of equipment and protective systems but with no autonomous function.				
Equipment groups	Equipment group I			Equipment group II	
	Equipment intended for use in mines, surface and underground parts			Equipment intended for use in other places	
Categories	Category 1		Category 2		Category 3
	Very high level of protection		High level of protection		Requisite level of protection during normal operation
Explosive atmosphere	Gases, vapours, mists			Dusts	
	G			D	
Explosion groups	Gases and vapours are classified in three explosion groups due to their special flammability. Their hazardous nature increases from explosion group IIA to IIC. The higher explosion group, e.g. IIC, includes the lower groups IIB and IIA.				
	IIA		IIB		IIC
Temperature classes	The admissible surface temperatures are divided into 6 temperature classes (T1-T6). Combustible gases and vapours can be classified in these temperature classes based on their ignition points. The following max. allowable surface temperatures of the equipment are valid for the temperature classes. A higher temperature class, e.g. T6, includes any lower temperature classes, e.g. T5 ...T1.				
	T1 ≤ 450 °C	T2 ≤ 300 °C	T3 ≤ 200 °C	T4 ≤ 135 °C	T5 ≤ 100 °C T6 ≤ 85 °C
Division into zones	The operator/employer shall classify all areas of his company, independently of the size of the company, into zones with explosion hazard and document them in the explosion protection document. The zones are defined based on the probability of the formation of explosive atmospheres.				
Gases Vapours Mists	Zone 0		Zone 1		Zone 2
	Zone 0 is a place in which an explosive atmosphere consisting of a mixture with air of flammable substances in the form of gas, vapour or mist is present continuously or for long periods or frequently.		Zone 1 is a place in which an explosive atmosphere consisting of a mixture with air or flammable substances in the form of gas, vapour or mist is likely to occur in normal operation occasionally.		Zone 2 is a place in which an explosive atmosphere consisting of a mixture with air of flammable substances in the form of gas, vapour or mist is not likely to occur in normal operation but, if it does occur, will persist for a short period only.
Dusts	Zone 20		Zone 21		Zone 22
	Zone 20 is a place in which an explosive atmosphere in the form of a cloud of combustible dust in air is present continuously, or for long periods or frequently.		Zone 21 is a place an explosive atmosphere in the form of a cloud of combustible dust in air is likely to occur in normal operation occasionally.		Zone 22 is a place an explosive atmosphere in the form of a cloud of combustible dust in air is not likely to occur in normal operation but, if it does occur, will persist for a short period only.

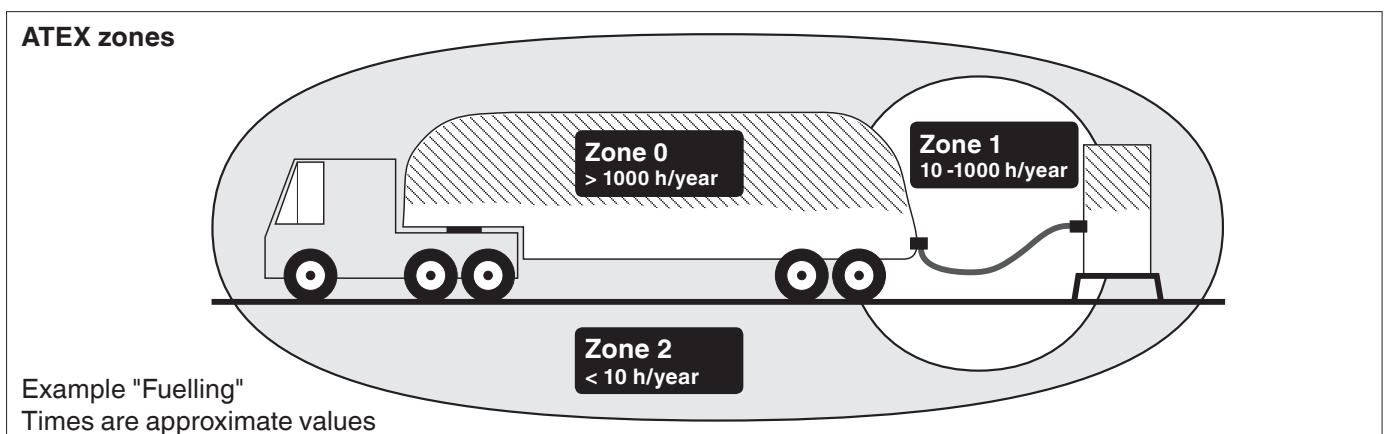



**Safety
solenoid valves,
one stage operation**

ATEX

on valve body: II3GD T3
on solenoid: II 3 G Ex mc nA IIB T3 Gc
II 3 D Ex mc IIIB T100°C Dc

MV ... X
MVD ... X

Technology

Solenoid valves for ATEX requirements II3GD.

Automatic shut-off valve acc. to EN 161 for gas burners and gas burning installations:

- Max. operating pressure up to 200 or 500 mbar
- without current closed
- fast opening
- main flow adjustable
- DC solenoid, rectifier wiring in connector box with **connecting cable 5 m**
- Pipe thread as per ISO 7/1
- Flange connection acc. to DIN 26 33, ISO 7005
- reliably operating, robust and maintenance-free

Media/use

MV ...X
MVD ... X

Suitable for gases of gas families 1, 2 and 3 and other neutral gases as well as air, smoke and exhaust gases. Version without non-ferrous material (S02) suitable for gases up to max. 0.1 vol. % H₂S, dry.

Approvals

ATEX
Manufacturer's declaration according to ATEX directive 94/9/EC:
II3GD

EC type-examination certificate according to the EC gas appliance directive:
CE-0085 AO 3219

EC type-examination certificate according to the EC pressure equipment directive:
CE0036

Function

The safety solenoid valve by DUNGS is an automatic shut-off valve activated by auxiliary power. The electromagnetic drive opens against the closing spring. The armature stroke can be limited by means of an adjustment screw (D function). If the auxiliary power (operating voltage) is interrupted, the closing spring closes the valve within 1 s.

MV ... X: solenoid valve, one stage operation, closed without current, fast opening, fast closing.

MVD ... X: solenoid valve, one stage operation, closed without current, fast opening, fast closing. The gas flow can be limited manually by means of the main flow setting.

Attention!

Read the operating and mounting instructions before putting the device into service.

Technical data ATEX solenoid valves	MV ... X, MVD ... X Safety solenoid valves, one stage operation
ATEX	II3GD
ATEX group	II
ATEX category	3
Atmosphere	Gas (G) and dust (D)
Temperature class	T3
Nominal diameter, DN Pipe thread acc. to DIN 2999, Rp Flanges	10 15 20 25 40 50 65 80 100 125 150 $\frac{3}{8}$ $\frac{1}{2}$ $\frac{3}{4}$ 1 $1\frac{1}{2}$ 2 Connection flanges as per DIN 2501 part 1 matching welding neck flanges as per DIN 2633, (PN 16) DN 40 - DN 150, ISO 7005-2 (PN 16)
Max. operating pressure	Up to 200 mbar (20 kPa): MV 2...; MVD 2... Up to 500 mbar (50 kPa): MV 5...; MVD 5...
Solenoid valve	Valve acc. to EN 161, class A, group 2, one stage operation
Closing time	< 1 s
Opening time	< 1 s at an ambient temperature of +20 °C
Main flow setting	Manually for MVD X
Material of the gas-bearing parts	Standard versions Housing: Aluminium, steel, brass Seals: NBR Versions without non-ferrous material Housing: Aluminium, steel Seals: NBR
Voltage / frequency	~(AC) 230 V (+10 % -15 %); 50-60 Hz - other voltages on request
Power / current consumption	See type overview
Duty cycle	Continuous duty
International protection	IP 54 as per IEC 529 (EN 60529)
Electrical connection	Connecting cable 5 m
Duty classification	MV X, MVD X Rp $\frac{3}{8}$ - Rp 2: max. 100/h MV X DN 40 - DN 100: max. 100/h MV X DN 125 - DN 150: max. 20/h MVD X DN 40 - DN 80: max. 100/h MVD X DN 100 - DN 150: max. 20/h
Sample and start gas connection	G $\frac{1}{4}$ DIN ISO 228 on both sides in the supply pressure area, additionally on the input side G $\frac{3}{4}$, as of DN 40 (flange)
Dirt trap	Integrated sieve, mesh size 1 mm
Temperature range	Ambient temperature: -15 °C to +60 °C Medium temperature: -15 °C to +60 °C Storage temperature: -30 °C to +80 °C
Mounting position	Solenoid standing vertically to lying horizontally
Limit switch	Mounting not permitted!
Valve check system	DSLCL pxVx (installation outside of Ex zone)

Flow diagram

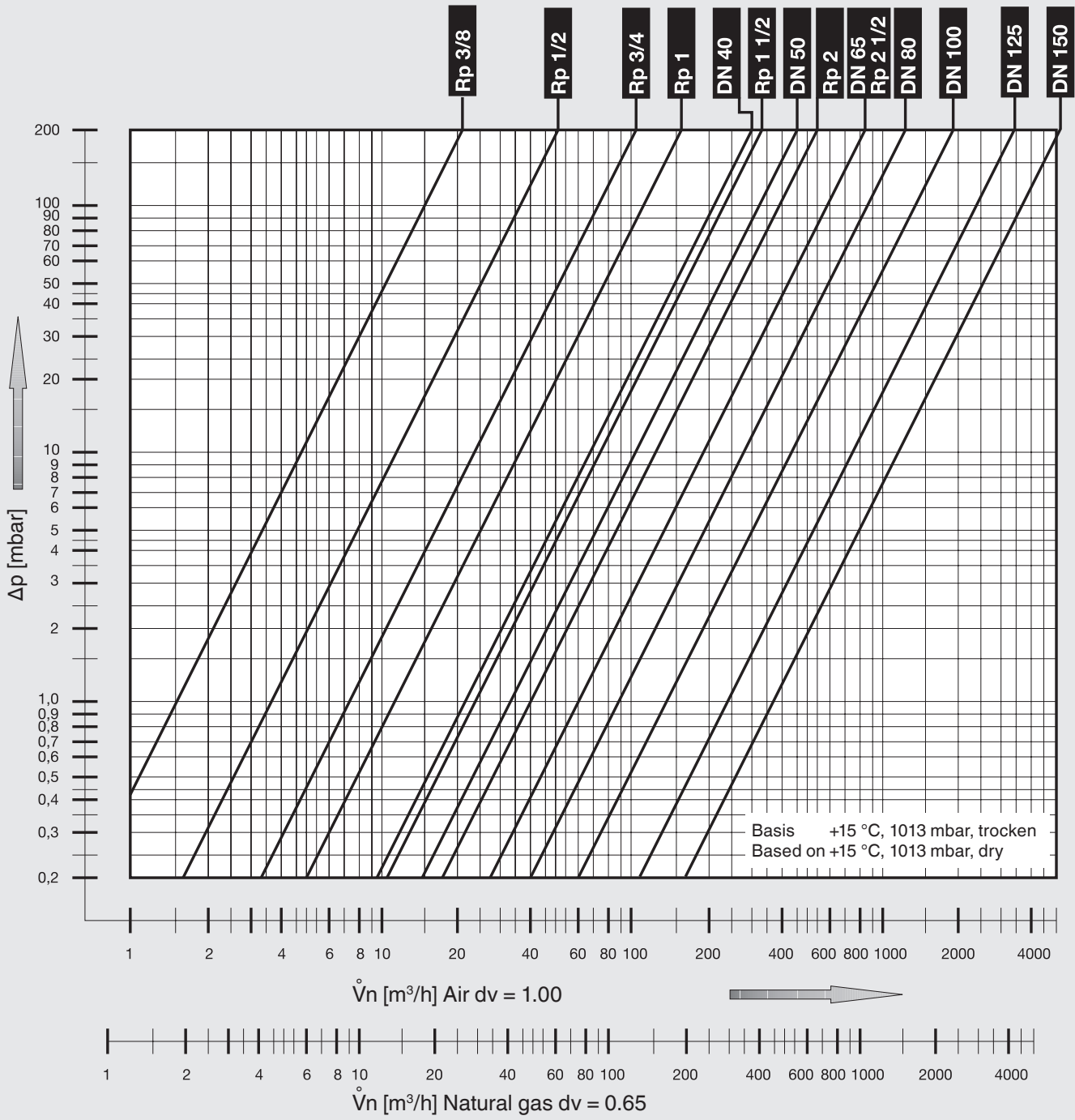

$$\dot{V}_{\text{gas used}} = \dot{V}_{\text{air}} \times f$$

$$f = \frac{\text{Dichte Luft / Spec. weight air}}{\text{Dichte des verwendeten Gases / Spec. weight of gas used}}$$

Gasart Type of gas	Dichte Spec. Wgt. [kg/m³]	dv	f
Erdgas Natural gas	0.81	0.65	1.24
Stadtgas City gas	0.58	0.47	1.46
Flüssiggas LPG	2.08	1.67	0.77
Luft Air	1.24	1.00	1.00

Dimensions [mm]
MVD 503 X - MVD 520 X
MVD 2040 S02 X
- MVD 2100 S02 X

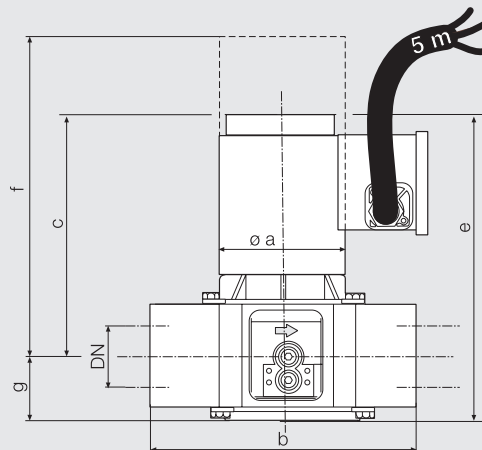
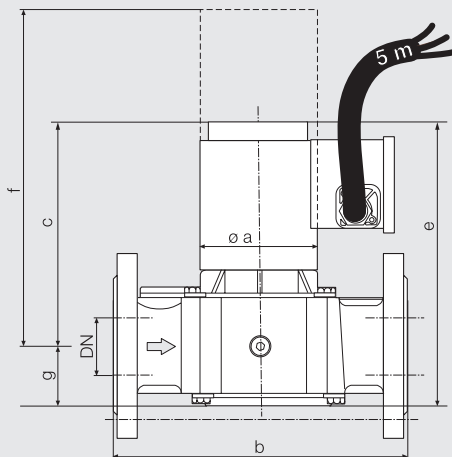

Dimensions [mm]
MV 5125 X
MV 2150 S02 X Viton
MV 5150 X
MVD 5100 X
MVD 2125 S02 X
MVD 2150 S02 X

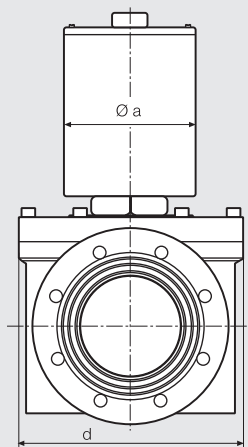
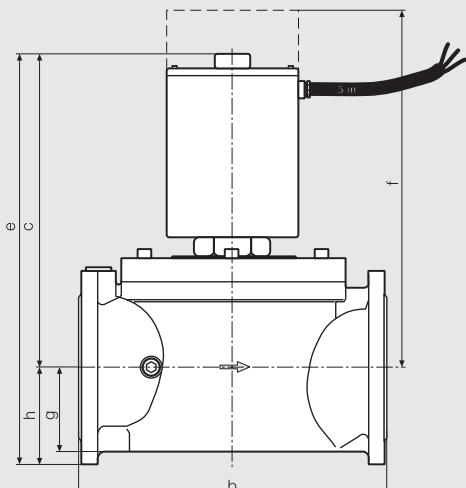

Type	P _{max.} [mbar]	DN / Rp	Solenoid number	Order number	P _{max.} [VA]	I _{max.} [VA] ~ (AC)230 V	Opening time	Dimensions [mm]								Weight [kg]
								øa	b	c	d	e	f	g	h	
MVD 503 X	500	Rp 3/8	100X	253011	17	0.08	< 1 s	50	60	90	75	113	190	20	1.6	
MVD 505 X	500	Rp 1/2	100X	253012	17	0.08	< 1 s	50	75	90	75	113	200	23	1.7	
MVD 507 S02 X	500	Rp 3/4	200X	253013	30	0.15	< 1 s	75	100	135	80	160	190	25	2.4	
MVD 510 X	500	Rp 1	200X	253014	30	0.15	< 1 s	75	110	135	90	165	190	30	3.3	
MVD 515 X	500	Rp 1 1/2	300X	253015	65	0.30	< 1 s	95	150	175	116	210	255	35	5.3	
MVD 520 X	500	Rp 2	400X	253016	100	0.48	< 1 s	115	170	190	130	235	300	45	9.5	
MVD 2040 S02 X	200	DN 40	300X	253017	65	0.30	< 1 s	95	200	170	150	230	255	40	6.2	
MVD 2050 S02 X	200	DN 50	300X	253018	65	0.30	< 1 s	95	230	170	165	230	255	45	8.4	
MVD 2065 S02 X	200	DN 65	400X	253019	100	0.48	< 1 s	115	290	215	185	275	320	55	13.4	
MVD 2080 S02 X	200	DN 80	500X	253020	80	0.42	< 1 s	130	310	250	200	305	360	70	18.7	
MVD 2100 S02 X	200	DN 100	550X	253021	100	0.48	< 1 s	150	350	310	240	395	480	85	100	30.8
MVD 2125 S02 X	200	DN 125	61EX	253022	90*	10**	< 1 s	170	400	406	290	531	514	112	125	54.5
MVD 2150 S02 X	200	DN 150	61EX	253023	90*	10**	< 1 s	170	480	439	290	582	547	125	143	62.7
MVD 5100 S02 X	500	DN 100	61EX	253031	90*	10**	< 1 s	170	350	360	240	418	600	85	100	39.7
MV 5125 X	500	DN 125	61EX	253032	90*	10**	< 1 s	170	400	406	290	531	514	112	125	53.1
MV 5150 X	500	DN 150	61EX	253033	90*	10**	< 1 s	170	480	439	290	582	547	125	143	62.1

*Electrical power when open
f = Space required for mounting the solenoid

** Switch-on current for approx. 3 s
d = Max. width



High-pressure switch for gas, air, flue and exhaust gases

Gas: II3G Ex nC IIB T6 Gc
 Dust: II3D Ex tc IIIB T75°C Dc
 Environment: -15 °C ≤ Ta ≤ +70 °C

GW...A4/2 HP X

Function Overpressure switch

GW...A4 HP/2 X Pressure switch in overpressure range

The pressure acts on the micro switch via the metal bellows against the force of the adjusting spring. The pressure switch works without auxiliary power.

Only GW...A4 HP/2 X

All gas-bearing parts are made of stainless steel 1.4541 and are suitable for:

- Biogas applications
- Aggressive media such as sulfuric acid with concentrations up to 1.0 vol. %

Differential pressure switch for gas, air, flue and exhaust gases

Gas: II3G Ex nC IIB T6 Gc
 Dust: II3D Ex tc IIIB T75°C Dc
 Environment: -15 °C ≤ Ta ≤ +70 °C

GGW...A4/2 X
 GGW...A4-U/2 X

Differential pressure switch function

GGW...A4/2 X and GGW...A4-U/2 X Differential pressure switch in overpressure and negative pressure range.

The differential pressure acts on the micro switch via the membrane against the force of the adjusting spring. The pressure switch works without auxiliary power.

Device selection

GGW...A4/2 X and GGW...A4-U/2 X

If the lower pressure p_2 (upper chamber) is a positive pressure compared to the atmosphere, type GGW...A4/2 X must be used.

If the lower pressure p_2 (upper chamber) is a negative pressure compared to the atmosphere, type GGW...A4-U/2 X must be used.

Overpressure switch

GGW...A4/2 X

Pressure connection G ¼

The control unit reacts on overpressure, which connects, disconnects or switches a circuit when exceeding or falling below a set nominal value. Simply acting pressure switch in overpressure range. The G ¼ pressure connection must not be closed.

Minimum pressure switch

GGW...A4-U/2 X

Pressure connection G ¼

The control unit reacts on negative pressure, which connects, disconnects or switches a circuit when exceeding or falling below a set nominal value. Simply acting pressure switch in negative pressure range. The G ¼ pressure connection must not be closed.

Technology

Adjustable pressure switches for ATEX requirements II3G and II3D.

The pressure switches are suitable for activating, deactivating or switching a circuit if the actual value of the pressure changes compared to the set nominal value.

The nominal value (switching point) is set by means of a setting wheel with scale.

Media/use

GW...A4 HP/2 X

GGW...A4/2 X

GGW...A4-U/2 X

Suitable for gases of gas families 1, 2 and 3 and other neutral gases as well as air, flue and exhaust gases.

Version without non-ferrous material, suitable for gases up to max. 0.1 vol. % H₂S, dry.

Approvals

ATEX

Manufacturer's declaration according to ATEX directive 94/9/EC: II3G and II3D

EC type-examination certificate according to the EC gas appliance directive:

CE-0085 AO 3220

EC type-examination certificate according to the EC pressure equipment directive:

CE0036

Attention!

Read the operating and mounting instructions before putting the device into service.

Switching function

With increasing pressure:

1 NC opens, 2 NO closes.

With decreasing pressure:

1 NC closes, 2 NO opens.

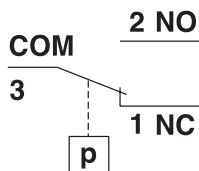

Technical data ATEX pressure switch	GW...A4/2 HP X Overpressure switch	GGW...A4/2 X GGW...A4-U/2 X Differential pressure switch
ATEX	II3G and II3D	
ATEX group	II	
ATEX category	3	
Atmosphere	Gas (G) and dust (D)	
Explosion group Maximum experimental safe gap	Gas: IIB Dust: IIIB	
Max. surface temperature	+75 °C	
Max. operating pressure	<p>GW 500 A4 HP X $p_{max} = 2 \text{ bar (Gas) @ setting range 0,1-0,15 bar}$ $p_{max} = 5 \text{ bar (Gas) @ setting range 0,15-0,5 bar}$</p> <p>GW 2000 A4 HP X $p_{max} = 5 \text{ bar (Gas)}$ GW 6000 A4 HP X $p_{max} = 8 \text{ bar (Gas)}$</p>	<p>GGW 3 A4/2 X up to GGW 150 A4/2 X 500 mbar (50 kPa)</p> <p>GGW 3 A4-U/2 X up to GGW 150 A4-U/2 X 500 mbar (50 kPa)</p>
Pressure connection	<p>p+: in the centre of the underside of the housing G ¼-female thread as per ISO 228: Gas or air</p>	<p>p+: in the centre of the underside of the housing G ¼-female thread as per ISO 228: Gas or air p+: laterally on the housing by means of screw plug G ¼: Gas or air p-: laterally on the underside of the housing G ⅛-female thread as per ISO 228: Gas or air</p>
Temperature range	<p>Ambient temperature: -15 °C to +70 °C Medium temperature: -15 °C to +70 °C Storage temperature: -30 °C to +80 °C</p>	
Material	<p>Bottom part of the housing Aluminium diecast Switch part: Polycarbonate Metal bellows: 1.4541 (stainless steel) Hood Zinc diecast, powder-coated Switching contact Standard: AG gilded (Au), suitable for DDC applications: DC 24 V; 0.02 A</p>	<p>Bottom part of the housing Aluminium diecast Switch part: Polycarbonate Membrane: NBR Hood Zinc diecast, powder-coated Switching contact Standard: Gilded Ag (Au), suitable for DDC applications: DC 24 V; 0.02 A</p>
Switching voltage	<p>AC eff. min. 24 V max. 250 V DC min. 24 V max. 48 V DDC-Application DC min. 5 V max. 24 V</p>	
Rated current	<p>AC eff. 10 A DDC-Application DC 20 mA</p>	
Switching current	<p>AC eff. min. 20 mA max. 6 A with $\cos \varphi 1$ AC eff. max. 3 A with $\cos \varphi 0.6$ DC min. 20 mA max. 1 A DDC-Application DC min. 5 mA max. 20 mA</p>	
Electrical connection	on screw-type terminals via cable entry ATEX M20x1.5 Line diameter 5 mm - 10 mm	
International protection	IP 65 as per IEC 529 (EN 60529)	
Adjustment	With increasing pressure in vertical mounting position. Optionally increasing or decreasing setting on site. Observe the change of the switching point with deviating mounting position.	
Adjustment tolerance	±15 % deviation of the switching point compared to the nominal value and installation in vertical mounting position	

Dimensions [mm]

GW...A4/2 HP X

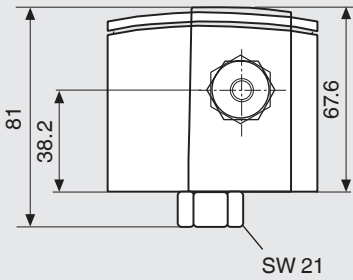

4 self-tapping cap screws
M3 x 14
longitudinal slot 0.8 and
recessed head DIN 7902-72

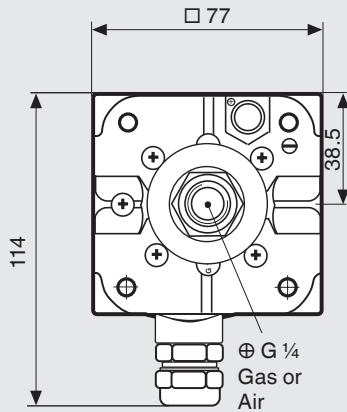
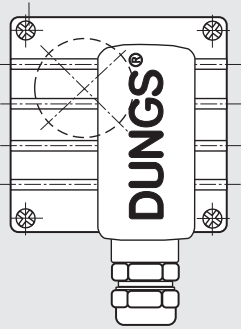

Dimensions [mm]

**GGW...A4/2 X
GGW...A4-U/2 X**

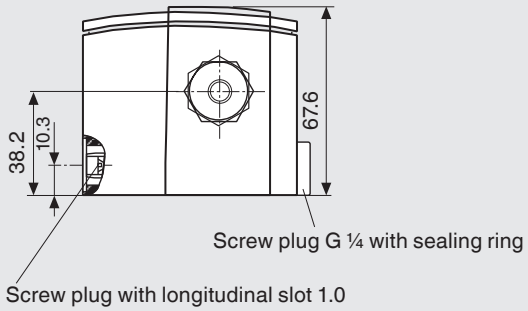

4 self-tapping cap screws
M3 x 14
longitudinal slot 0.8 and
recessed head DIN 7902-72

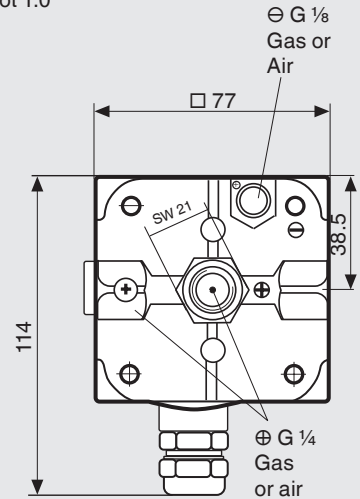
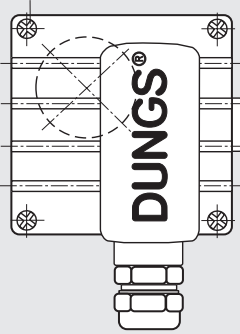

Mounting positions (observe the change of the switching point if mounting position differs from standard)

	<p>Standard mounting position</p>										
	<p>The pressure switch is activated at a higher pressure when mounted horizontally:</p> <table border="0"> <tr> <td>GW 500 A4/2 HP X</td> <td>approx. + 10 mbar</td> </tr> <tr> <td>GW 2000 A4/2 HP X</td> <td>approx. + 20 mbar</td> </tr> <tr> <td>GW 6000 A4/2 HP X</td> <td>approx. + 80 mbar</td> </tr> <tr> <td>GGW ... A4/2 X</td> <td>approx. + 0.5 mbar</td> </tr> <tr> <td>GGW ... A4-U/2 X</td> <td>approx. + 0.5 mbar</td> </tr> </table>	GW 500 A4/2 HP X	approx. + 10 mbar	GW 2000 A4/2 HP X	approx. + 20 mbar	GW 6000 A4/2 HP X	approx. + 80 mbar	GGW ... A4/2 X	approx. + 0.5 mbar	GGW ... A4-U/2 X	approx. + 0.5 mbar
GW 500 A4/2 HP X	approx. + 10 mbar										
GW 2000 A4/2 HP X	approx. + 20 mbar										
GW 6000 A4/2 HP X	approx. + 80 mbar										
GGW ... A4/2 X	approx. + 0.5 mbar										
GGW ... A4-U/2 X	approx. + 0.5 mbar										
	<p>The pressure switch is activated at a lower pressure if mounted horizontally overhead:</p> <table border="0"> <tr> <td>GW 500 A4/2 HP X</td> <td>approx. - 10 mbar</td> </tr> <tr> <td>GW 2000 A4/2 HP X</td> <td>approx. - 20 mbar</td> </tr> <tr> <td>GW 6000 A4/2 HP X</td> <td>approx. - 80 mbar</td> </tr> <tr> <td>GGW ... A4/2 X</td> <td>approx. - 0.5 mbar</td> </tr> <tr> <td>GGW ... A4-U/2 X</td> <td>approx. - 0.5 mbar</td> </tr> </table>	GW 500 A4/2 HP X	approx. - 10 mbar	GW 2000 A4/2 HP X	approx. - 20 mbar	GW 6000 A4/2 HP X	approx. - 80 mbar	GGW ... A4/2 X	approx. - 0.5 mbar	GGW ... A4-U/2 X	approx. - 0.5 mbar
GW 500 A4/2 HP X	approx. - 10 mbar										
GW 2000 A4/2 HP X	approx. - 20 mbar										
GW 6000 A4/2 HP X	approx. - 80 mbar										
GGW ... A4/2 X	approx. - 0.5 mbar										
GGW ... A4-U/2 X	approx. - 0.5 mbar										
	<p>If mounted in intermediate mounting position, the pressure switch is activated at a max. higher or lower pressure compared to the set nominal value.</p>										

Type	Version	p_{max} [mbar]	Order number	Adjustment range [mbar]	Switching difference Δp [mbar]	Inter-national protection	
ATEX Pressure control device II3G and II3D							
	GW ... A4/2 HP X Pressure control device [-Au-M-V0]	GW 500 A4/2 HP X	2000 @ 100-150 5000 @ 150-500	251984	100 – 500	≤ 30	IP 65
		GW 2000 A4/2 HP X	5000	251985	400 – 2000	≤ 50 @ 400-1000 ≤ 100 @ 1000-2000	
	GW 6000 A4/2 HP X	8000	251986	1000 – 6000	≤ 300		
GGW ... A4/2 X Differential pressure switch (overpressure) [Au-M-MS9-V0-VS3]	GGW 3 A4/2 X	500	245810	0.4 – 3.0	≤ 0.3	IP 65	
	GGW 10 A4/2 X		248694	1.0 – 10.0	≤ 0.5		
	GGW 50 A4/2 X		245811	2.5 – 50	≤ 1		
	GGW 150 A4/2 X		248695	30 – 150	≤ 3		
GGW ... A4-U/2 X Differential pressure switch (negative pressure) [Au-M-MS9-V0-VS3]	GGW 3 A4-U/2 X	500	248390	-0.4 – -3.0	≤ 0.3	IP 65	
	GGW 10 A4-U/2 X		248391	-1.0 – -10.0	≤ 0.5		
	GGW 50 A4-U/2 X		246180	-2.5 – -50	≤ 1		
	GGW 150 A4-U/2 X		248392	-30 – -150	≤ 3		
Accessories							
Gauge connection G ¼ with sealing ring (1x)			266042	only for GGW ... A4/2 X, GGW ... A4-U/2 X			
Mounting kit Mounting bracket, metal			230288				

**ATEX Product Range
ATEX II3GD**

**Safety solenoid valve,
one stage operation**
MV ... X, MVD ... X
Differential pressure switch
GGW...A4/2 X
GGW...A4-U/2 X
High-pressure switch
GW...A4/2 HP X



ATEX conformity certificate

The original can be found under www.dungs.com

**Konformitätserklärung
Conformity Certificate**

DUNGS®
Combustion Controls

Die **Karl Dungs GmbH & Co. KG** bescheinigt hiermit, daß die in dieser Übersicht genannten Produkte die Anforderungen folgender Richtlinie erfüllen:

Karl Dungs GmbH & Co. KG certify that the products specified in this overview fulfil the basic requirements of the:

ATEX-Richtlinie 94/9/EG	ATEX-Directive 94/9/EC	Produkte_Products
Die Anforderungen werden erfüllt durch Übereinstimmung mit:	The requirements have been assured by compliance with:	MVD 503 X 230 VAC IP54 MVD 505 X 230 VAC IP54 MVD 505 X 24 VDC IP54 MVD 507 S02 X 230 VAC IP54 MVD 507 S02 X 24 VDC IP54 MVD 510 X 230 VAC IP54 MVD 510 X 24 VDC IP54 MVD 515 X 230 VAC IP54 MVD 520 X 230 VAC IP54 MVD 2040 S02 X 230 VAC IP54 MVD 2050 S02 X 230 VAC IP54 MVD 2065 S02 X 230 VAC IP54 MVD 2080 S02 X 230 VAC IP54 MVD 2100 S02 X 230 VAC IP54 MVD 2125 S02 X 230 VAC IP54 MVD 2150 S02 X 230 VAC IP54 MVD 2040 S02 X 24 VDC IP54 MVD 2050 S02 X 24 VDC IP54 MVD 2065 S02 X 24 VDC IP54 MVD 2080 S02 X 24 VDC IP54 MVD 2100 S02 X 24 VDC IP54 MVD 2125 S02 X 24 VDC IP54 MVD 2150 S02 X 24 VDC IP54 MVD 5100 S02 X 230 VAC IP54 MV 5125 X 230 VAC IP54 MV 5150 X 230 VAC IP54
EN 60079-0:2012 +A11:2013 EN 60079-15:2010 EN 60079-18:2009 EN 60079-31:2009 EN 13463-1:2009	EN 60079-0:2012 +A11:2013 EN 60079-15:2010 EN 60079-18:2009 EN 60079-31:2009 EN 13463-1:2009	
		Kennzeichnung/Marking Auf Ventilkörper/on valve body Ⓢ II 3 GD T3 Auf Magnet/on solenoid Ⓢ II 3 G Ex mc nA IIB T3 Gc Ⓢ II 3 D Ex mc IIIB T100°C Dc -15 °C ≤ Ta ≤ +60 °C

Dipl.-Ing. (BA) Karl Dungs
Chief Executive Officer
Karl Dungs GmbH & Co. KG
Urbach, 16 February 2015

**Konformitätserklärung
Conformity Certificate**

DUNGS®
Combustion Controls

Die **Karl Dungs GmbH & Co. KG** bescheinigt hiermit, daß die in dieser Übersicht genannten Produkte die Anforderungen folgender Richtlinie erfüllen:

Karl Dungs GmbH & Co. KG certify that the products specified in this overview fulfil the basic requirements of the:

ATEX-Richtlinie 94/9/EG	ATEX-Directive 94/9/EC	Produkte_Products
Die Anforderungen werden erfüllt durch Übereinstimmung mit:	The requirements have been assured by compliance with:	Druckwächter für Gas und Luft Pressure switch for gas and air GGW xx A4/2 X-Au-M-MS9-V0-VS3 GGW xx A4-U/2 X-Au-M-MS9-V0-VS3 GW xx A4/2 HP X-Au-M-V0
EN 60079-0:2012 +A11:2013 EN 60079-15:2010 EN 13463-1:2009	EN 60079-0:2012 +A11:2013 EN 60079-15:2010 EN 13463-1:2009	
		Kennzeichnung/Marking ⓈII3G Ex nC IIB T6 Gc ⓈII3D Ex tc IIIB T75°C Dc -15 °C ≤ Ta ≤ + 70 °C

Dipl.-Ing. (BA) Karl Dungs
Chief Executive Officer
Karl Dungs GmbH & Co. KG
Urbach, 16 February 2015

Subject to technical modification in the interest of technical progress.



Company address
Karl Dungs GmbH & Co. KG
Siemensstraße 6-10
D-73660 Urbach, Germany
Phone +49 (0)7181-804-0
Fax +49 (0)7181-804-166

Postal address
Karl Dungs GmbH & Co. KG
Postfach 12 29
D-73602 Schorndorf, Germany
e-mail: info@dungs.com
Internet: www.dungs.com